

 **Power Belt Skiver**
Safety and Operating Manual

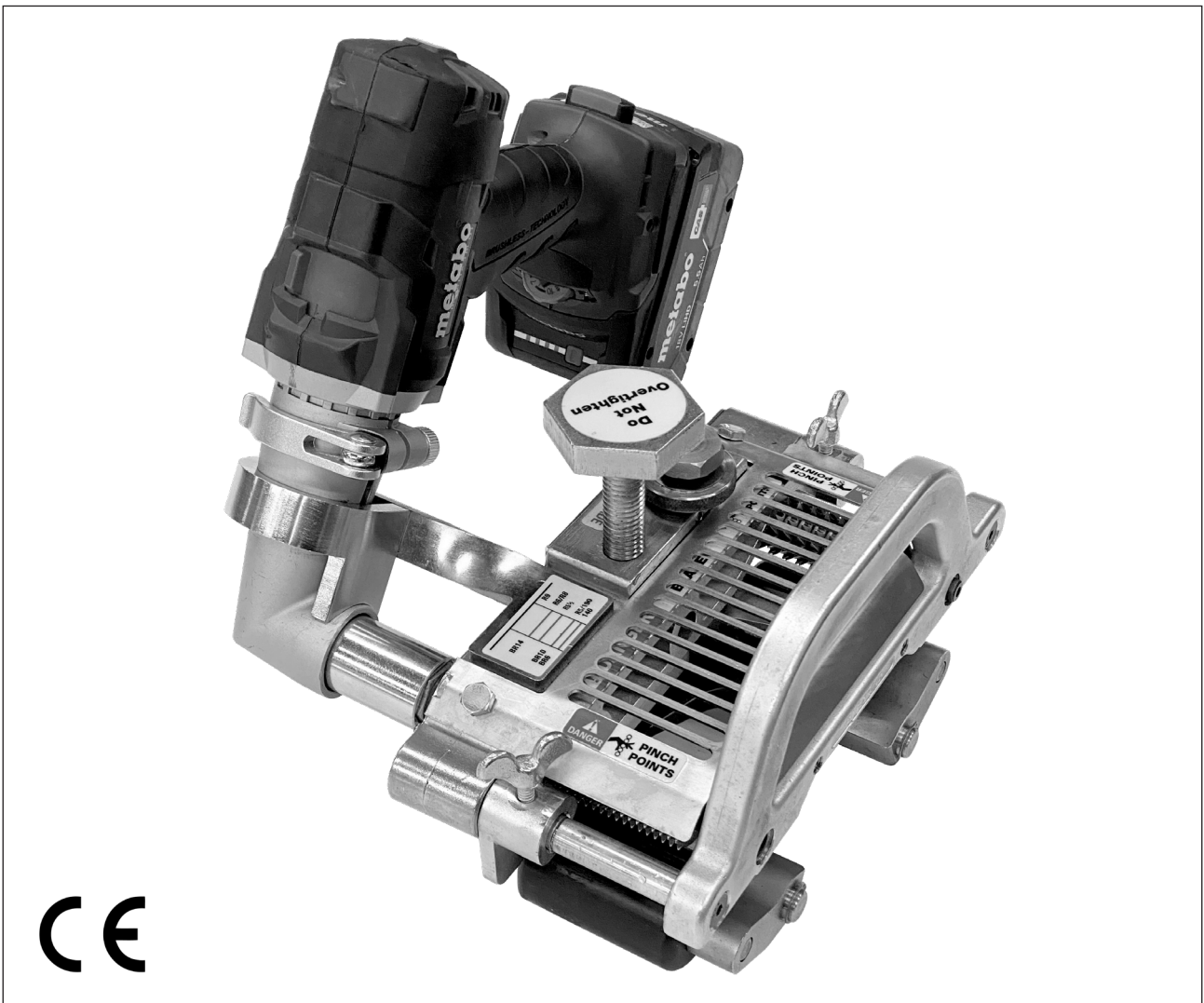

 **WARNING**

IMPROPER OR UNSAFE use of this power tool can result in death or serious bodily injury! This manual contains important information about product function and safety. Please read and understand this manual BEFORE operating the power tool. Please keep this manual available for other users and owners before they use the power tool. This manual should be stored in a safe place.

Table of Contents

Main Components..... 2

Tool Specifications..... 2

General Safety Rules..... 3-6

Operation of Cordless Electric Drill..... 6

Power Belt Skiver Operation..... 7

Tool Maintenance–Changing the Blade 8

Tool Maintenance–Sharpening the Blade 8

Main Components

1. Front Drive Roller
2. Rear Drive Roller
3. Fence Wing Nuts
4. Clamp Adjusting Screw
5. Blade Adjusting Screw
6. Jam Nut
7. Cordless Electric Drill
8. Roller Guards
9. Metal Fence
10. Grip Rollers

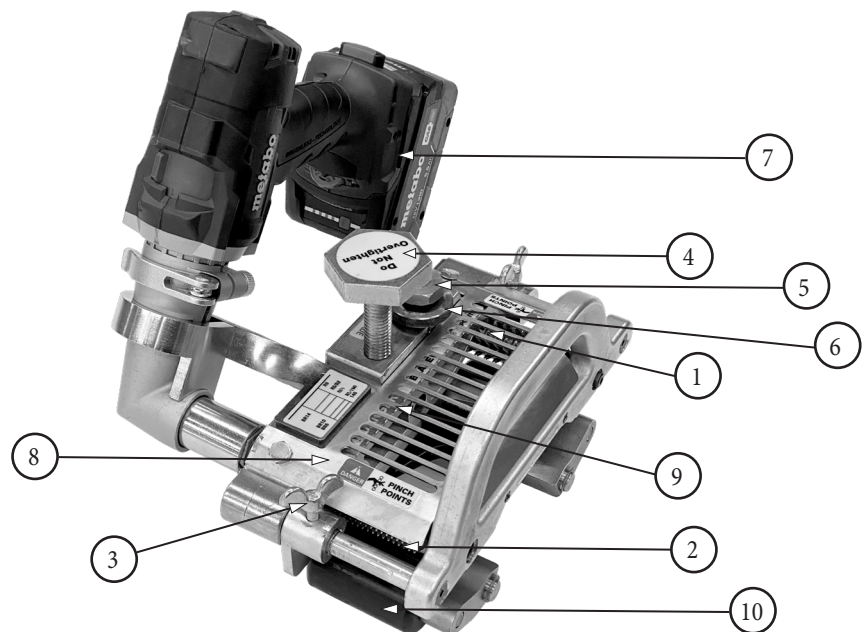

DO NOT carry tool by electric drill handle. It is recommended that you place tool in carrying case for traveling extended distances.

Tool Specifications

FSK2MP			
Specifications		Specifications	
Tool Description		Skive Capacity	
Weight	10.0 kg	Belt Thickness	6.5 - 32 mm
Blade Material	Durable Tool Steel	Skive Depth	1.5 - 9.5 mm
Blade	Standard (FSK-1B)	Skive Width	Up to 64 mm
Drill Description			
Drill – Make and Model	Metabo BS 18 LTX-3 BL QI		
Charger Power Source	120V		
Battery – Amp Hour	5.5AH		

Power Belt Skiver

General Safety Rules

—Save These Instructions—

Signal words:

“DANGER” indicates an imminently hazardous situation which, if not avoided, will result in death or serious injury. The signal word is limited to the most extreme situations.

“WARNING” indicates a potentially hazardous situation which, if not avoided, could result in death or serious injury.

“CAUTION” indicates a potentially hazardous situation which, if not avoided, may result in minor or moderate injury. It may also be used to alert against unsafe practices.

Safety Symbol



This international safety symbol is used to identify and call attention to specific safety matters.

Safety Information

To avoid severe personal injury or property damage, read carefully and understand the following Safety Precautions.

1. WORK AREA

⚠ CAUTION

Keep your work area clean and well lit. Cluttered benches and dark areas invite accidents.

⚠ DANGER

Do not operate power tools in explosive atmospheres, such as in the presence of flammable liquids, gases, or dust. Power tools create sparks, which may ignite the dust or fumes.

⚠ CAUTION

Keep bystanders, children, and visitors away while operating a power tool. Distractions can cause you to lose control.

⚠ WARNING

Never leave tool until it comes to a complete stop.

⚠ CAUTION

Operation of gear units is permitted at ambient temperatures between -20°C and $+40^{\circ}\text{C}$. However, for temperatures between -20°C and -10°C , unit may only start up after it has been progressively and evenly pre-heated, or otherwise initially operated unloaded. Load may then be connected to the output shaft when the gear unit has reached the temperature of -10°C or higher.

2. ELECTRICAL SAFETY

⚠ DANGER

Double Insulated tools are equipped with a polarized plug (one blade is wider than the other). This plug will fit in a polarized outlet only one way. If the plug does not fit fully in the outlet, reverse the plug. If it still does not fit, contact a qualified electrician to install a polarized outlet. Do not change the plug in any way. Double Insulation eliminates the need for the three wire grounded power cord and grounded power supply system.

FLEXCO

General Safety Rules

⚠️ WARNING

Avoid body contact with grounded surfaces such as pipes, radiators, ranges, and refrigerators. There is an increased risk of electric shock.

⚠️ WARNING

Do not expose power tools to rain or wet conditions. Water entering a power tool will increase the risk of electric shock.

⚠️ CAUTION

Ensure the switch is in the off position before inserting battery pack. Inserting the battery pack into power tools that have the switch on invites accidents.

Recharge only with the charger specified by the manufacturer. A charger that is suitable for one type of battery pack may create a risk of fire when used with another battery pack.

Use power tools only with specifically designated battery packs. Use of any other battery packs may create a risk of injury and fire. When battery pack is not in use, keep it away from other metal objects like paper clips, coins, keys, nails, screws, or other small metal objects that can make a connection from one terminal to another. Shorting the battery terminals together may cause burns or a fire.

Under abusive conditions, liquid may be ejected from the battery, avoid contact. If contact accidentally occurs, flush with water. If liquid contacts eyes, additionally seek medical help. Liquid ejected from the battery may cause irritation or burns.

3. PERSONAL SAFETY

⚠️ WARNING

Stay alert, watch what you are doing and use common sense when operating a power tool. Do not use tool while tired or under the influence of drugs, alcohol, or medication. A moment of inattention while operating power tools may result in serious personal injury.

⚠️ WARNING

Dress properly. Do not wear loose clothing or jewelry. Contain long hair. Keep your hair, clothing, and gloves away from moving parts. Loose clothes, jewelry, or long hair can be caught in moving parts.

⚠️ WARNING

Avoid accidental starting. Be sure switch is off before plugging in or before battery is inserted. Carrying tools with your finger on the switch or plugging in tools that have the switch on invites accidents.

⚠️ WARNING

Do not overreach. Keep proper footing and balance at all times. Proper footing and balance enables better control of the tool in unexpected situations.

⚠️ CAUTION

Use safety equipment. Always wear eye protection. Dust mask, non-skid safety shoes, hard hat, or hearing protection must be used for appropriate conditions.

⚠️ WARNING

Never alter or remove safety devices.

⚠️ WARNING

Keep your hands and fingers away from all moving parts, e.g. the blade, at all times.

4. TOOL USE AND CARE

⚠️ WARNING

Always use belt skiver on a level, firm surface. Skiving is only allowed when operating the machine with one hand on the handle and the other on the drill.

General Safety Rules

⚠️ WARNING

Keep lubricants away from the blade, the drive rollers, and the belt to prevent slippage.

⚠️ CAUTION

Do not force tool.

⚠️ WARNING

Do not use tool if switch does not turn it on or off. Any tool that cannot be controlled with the switch is dangerous and must be repaired.

⚠️ WARNING

Remove battery before making any adjustments, changing accessories, or storing the tool. Such preventive safety measures reduce the risk of starting the tool accidentally.

⚠️ WARNING

Store idle tools out of reach of children and other untrained persons. Tools are dangerous in the hands of untrained users.

⚠️ CAUTION

Maintain tools with care. Keep cutting tools sharp and clean. Properly maintained tools, with sharp cutting edges are less likely to bind and are easier to control.

⚠️ CAUTION

Check for misalignment or binding of moving parts, breakage of parts, and any other condition that may affect the tool's operation. If damaged, have the tool serviced before using. Many accidents are caused by poorly-maintained tools.

5. SERVICE AND MAINTENANCE

⚠️ WARNING

Tool service must be performed only by qualified repair personnel. Service or maintenance performed by unqualified personnel could result in a risk of injury.

⚠️ CAUTION

When servicing a tool, use only identical replacement parts. Use of unauthorized parts or failure to follow Maintenance Instruction may create a risk of electric shock or injury.

⚠️ DANGER

Do not use power tools if the plastic housing or handle is cracked. Cracks in the tool's housing or handle can lead to electric shock. Such tools should not be used until repaired.

⚠️ CAUTION

Do not wipe plastic parts with solvent. Solvents such as gasoline, thinner, benzene, carbon tetrachloride, and alcohol may damage and crack plastic parts. Do not wipe them with such solvents. Wipe plastic parts with a soft cloth lightly dampened with soapy water and dry thoroughly.

⚠️ WARNING

NEVER use a tool which is defective or operating abnormally. If the tool appears to be operating unusually, making strange noises, or otherwise appears defective, stop using it immediately and arrange for repairs.

⚠️ WARNING

Before performing any belt skiver maintenance, remove battery from tool and follow all procedures noted in manual.

Power Belt Skiver

General Safety Rules

6. BELT SKIVER SAFETY

!WARNING

Ensure drive and rear roller guards are in place before operating.

!WARNING

Never hold piece being cut in your hands or across your leg. It is important to support the work properly to minimize body exposure, blade binding, or loss of control.

!WARNING

Do not run the skiver while carrying it. Accidental contact with the spinning roller could result in serious personal injury.

!CAUTION

Do not use a dull or damaged blade.

7. REPLACING THE SKIVER BLADE

!WARNING

Always wear cut-proof safety gloves and safety glasses when replacing blade. Blade is razor sharp, treat it accordingly.

!WARNING

Before performing a blade replacement, remove battery from tool and follow all procedures noted in manual.

!WARNING

Only authorized and trained technicians should work on the skiver.

!WARNING

Test the skiver after blade replacement to make sure that it can be used safely.

Operation of Cordless Electric Drill



1. For normal use, operate in Reverse Direction; press drilling direction button for reverse direction operation.



2. Operate in Maximum Torque Mode only; turn the dial to indicate drill mode.

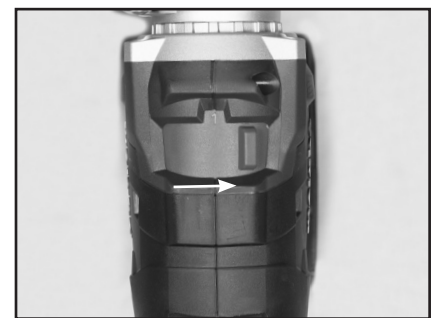

3. Cutting Speed Adjustment; adjust Electric Drill to low speed by moving switch to low speed. For best results, always operate skiver in low speed.

Power Belt Skiver

Power Belt Skiver Operation

For best results: Store in a clean, dry area. Do not throw or drop tool. Use only on belts between 6.5 mm and 32 mm thick.

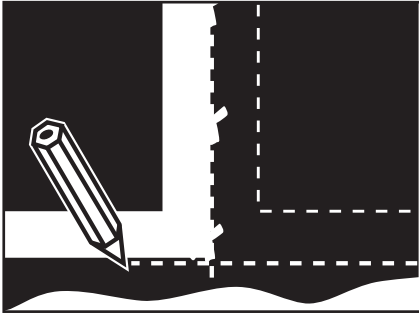

1. Cut belt using centerline method.
NOTE: For easier skiving, clean belt and use only sharp, undamaged blades.

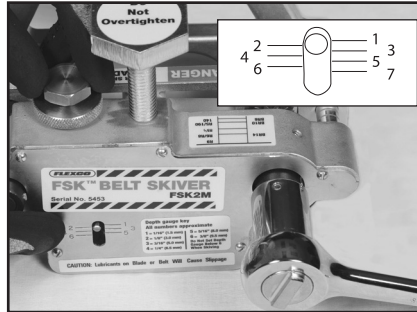

2. For new tool, carefully remove the protective coating on the blade. Turn Blade Adjusting Screw to select desired cutting depth. Tighten Jam Nut.

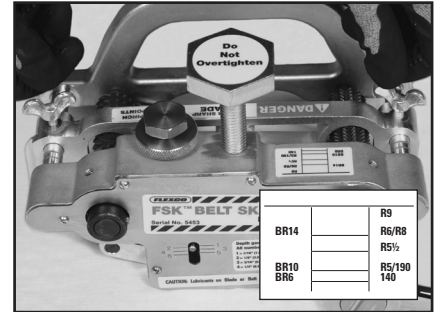

3. Adjust end wing nuts on metal fence to move fence to appropriate setting.



4. Turn Clamp Adjusting Screw counter-clockwise to loosen grip rollers. Position edge of belt against Fence – belt should just touch blade edge.

5. Turn Clamp Adjusting Screw clockwise to tighten Front Drive Rollers against belt. **Do not overtighten or cut may be deeper than expected.** Flexco recommends testing skiver on belt sample before skiving actual belt to ensure skive depth is appropriate.



6. Note skive direction and set tool to reverse. Once belt reaches Rear Drive Rollers, turn Clamp Adjusting Screw counter-clockwise 1/4 rotation.

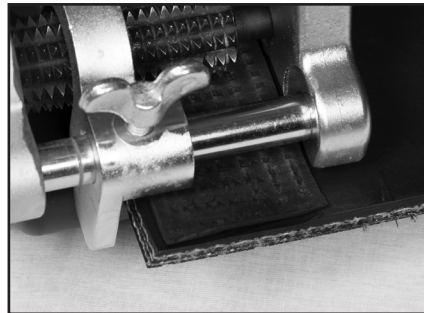

7. When skiving, scrap cut should remain in contact with belt. Scrap cut and Belt should feed under Rear Drive Rollers.



8. Advance skiver in a controlled manner across width of belt. Ensure belt is against Fence. Advance skiver completely off belt to complete cut. Remove scrap cut. Repeat steps 1-8 on other belt end.



Power Belt Skiver

Tool Maintenance—Changing the Blade

If the Belt Skiver is difficult to operate, the blade may be worn and need replacement. Unplug drill from power source. Always wear cut-proof safety gloves and safety glasses when replacing blade.

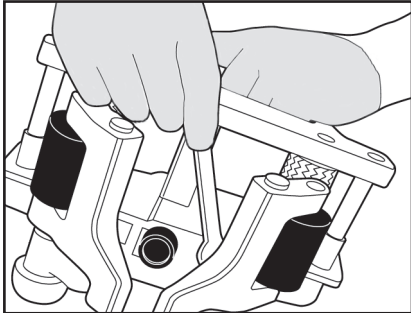

Changing the Blade: Turn blade adjusting screw to raise blade and turn clamp adjusting screw to lower grip rollers. Using a $\frac{7}{16}$ box type wrench, remove the $\frac{1}{4}$ -20 bolt from the blade holder.

WARNING: Use caution when handling blade. Take the old blade out and replace with a new blade. Retighten bolt.

Fastener Size	Additional Skiver Settings
R2, #1, 375	140/BR6
550, #1½	R-5/190/BR10
#2¼	R6/R8/BR14
#2½, #3	R9

Tool Maintenance—Sharpening the Blade

If the Belt Skiver is difficult to operate, the blade may be worn and need sharpening. Unplug drill from power source. Always wear cut-proof safety gloves and safety glasses when sharpening blade.

Sharpening the Blade: Use included sharpening stone. **NOTE:** The blade can be sharpened while attached to tool. For easier sharpening, turn clamp adjusting screw to lower grip rollers, turn blade adjusting screw to lower blade, turn fence screw to move fence to side.

WARNING: Always use caution when sharpening razor sharp blade.

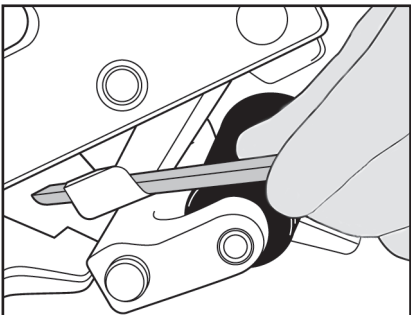

1. Using rounded side of sharpening stone, sharpen bevel on the curved portion of the blade.

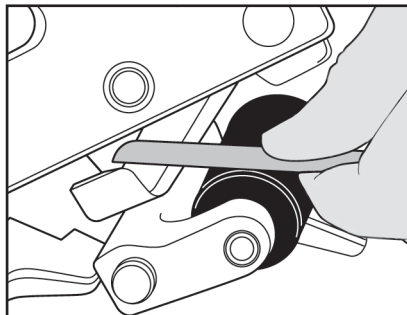

2. Using flat side of sharpening stone, sharpen bevel on the top-side of the blade.

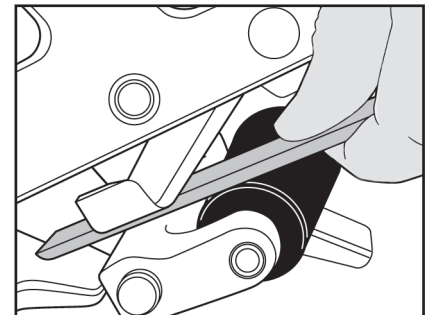

3. Using flat side of sharpening stone, sharpen bottom edge of blade flat.

Flexco Europe GmbH • Maybachstrasse 9 • 72348 Rosenfeld • Germany
Tel: +49-7428-9406-0 • Fax: +49-7428-9406-260 • E-mail: europe@flexco.com

Visit www.flexco.com for other Flexco locations and products.

©2023 Flexible Steel Lacing Company. 03-16-23. For reorder: 108613

