



---

# TUG™ HD® BELT CLAMP

## Safety and Operation Manual

---

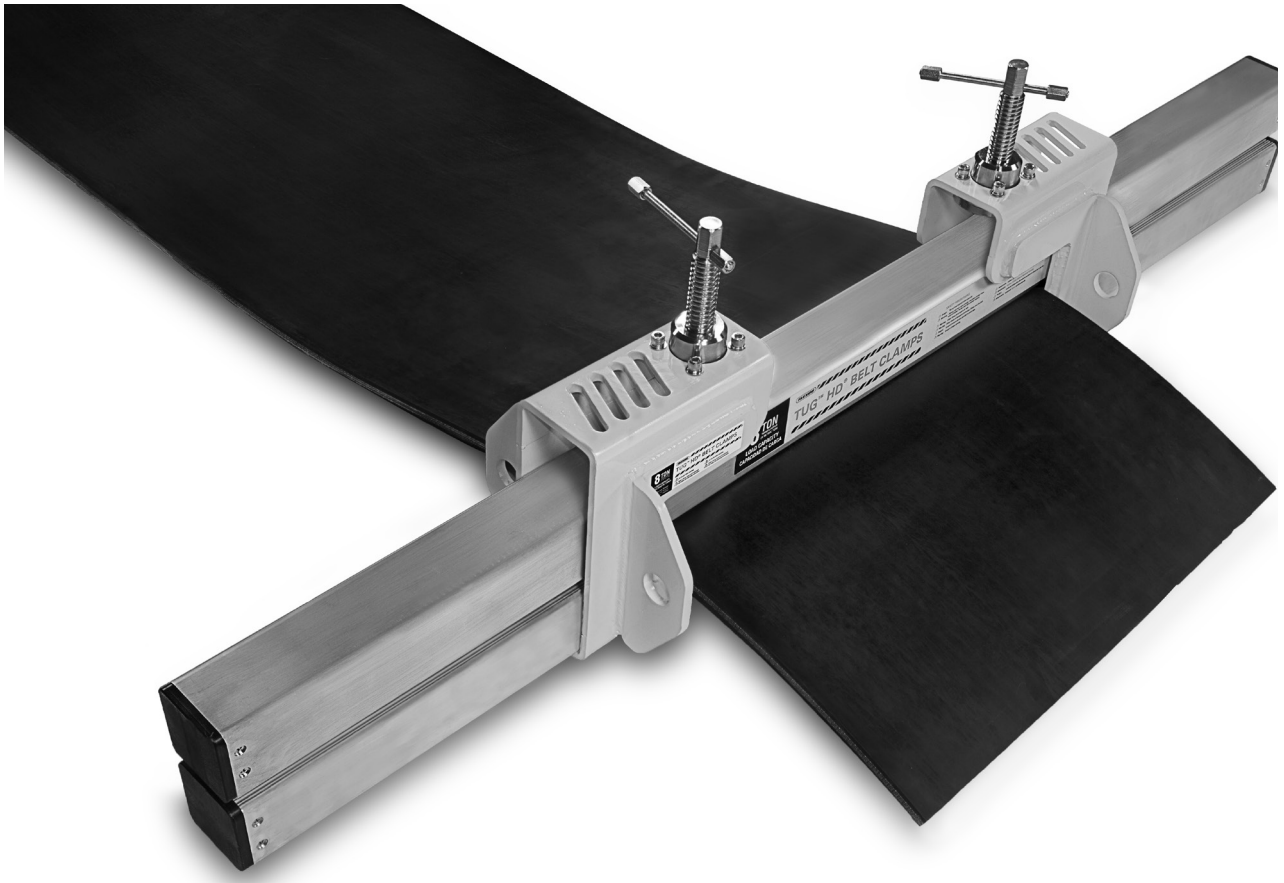

### **WARNING**

Improper use of this tool can result in serious bodily injury! This manual contains important information about product function and safety. Please read and understand this manual BEFORE operating the tool. Please keep this manual available for other users and owners before they use the tool. This manual should be stored in a safe place.

# Table of Contents

System Components ..... 3

Introduction ..... 3

General Safety Rules..... 4-5

Pre-Operative Checklist ..... 6

Operational Instructions ..... 7-8

## **Limited Warranty**

Flexco warrants to the original purchaser that this product is free from defects in material and workmanship, and agrees to repair or replace, at Flexco's option, any defective product within 1 year from the date of purchase. This warranty is not transferable. It only covers damage resulting from defects in material or workmanship, and it does not cover conditions or malfunctions resulting from normal wear, neglect, abuse, accident or repairs attempted or made by other than our regional repair center or authorized warranty service center.

To obtain warranty service, return the product at your expense together with proof of purchase to Flexco or a Flexco authorized distributor.

# System Components

Belt Clamp System	
1.	Clamp end
2.	Clamp end screw and T-handle
3.	Upper clamp bar
4.	Lower clamp bar
5.	Grip surface
6.	Lug
7.	Come-along

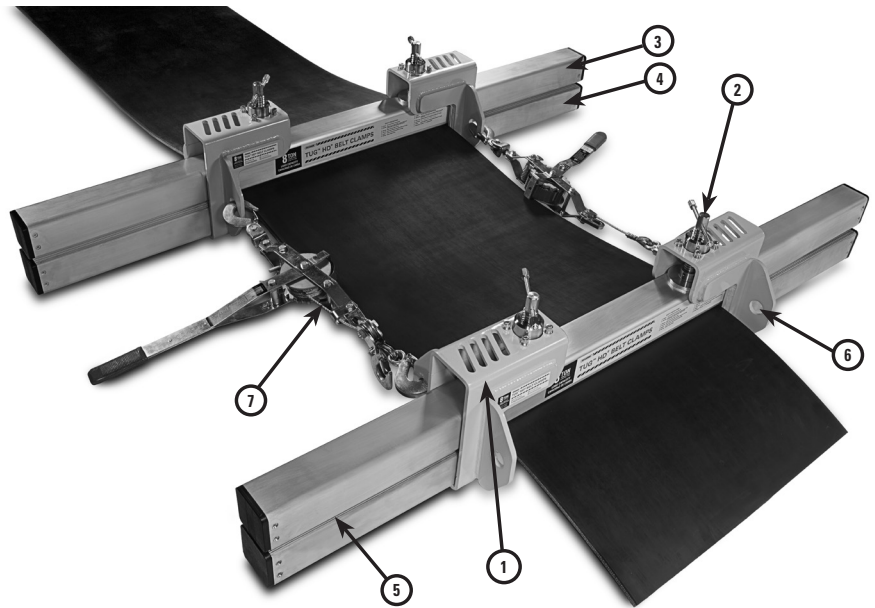

## Maximum Belt Thickness and Rated Load Capacity

TUG™ HD® Belt Clamps Specifications				
Version	Maximum Belt Thickness	Clamp Screw Torque	Rated Load Capacity	Safety Factor*
TUG6	2" (50 mm)	200 Lb-Ft (270 N-m)	6 Metric Tons (13,200 lbs)	2.0
TUG8	2.25" (55 mm)	200 Lb-Ft (270 N-m)	8 Metric Tons (17,600 lbs)	2.0

\*When using (2) aluminum bars on belt widths  $\leq 72"$  (1800 mm) the system prevents belt slip until 2.0X the rated load capacity. Equivalent safety factor for (2) steel bars is 1.4X. Clamp components are rated 3X in structural performance. The Tug HD Belt Clamp testing was administered by an accredited and certified test lab using PVC and multi-ply rubber conveyor belt types. The belt was secured in the test sample with clamping load by bolt torque of 200 Lb-Ft (270 N-m). A gradually increasing tensile load was applied to each test clamp assembly until the belt clamps slipped. New belt samples were used for each test. Safety Factor is defined as: Maximum Pulling Load / Rated Load Capacity of the clamp assembly (2 clamp ends and 2 bars). Belt Slip is defined as the condition when the belt pulling load exceeds the controlled clamping load by the bolt screw. The pulling load is also dependent on the friction generated by the belt type as well as the clamp bar grip surface.

## Introduction

### Belt Clamping Operations

The Flexco TUG™ HD® Belt Clamps are classified as portable or pulling Clamps. They are used to restrain or pull a conveyor belt. The conveyor belting may be under no operating tension, but may be subject to inherent tensions as a result of the slope of the conveyor.



## TUG™ HD® Belt Clamp

---

### Dual Clamp Application

Maintenance of a conveyor belt may require cutting and skiving of a stationary belt. Adjacent cross sections may be clamped and drawn together to affect splicing. A typical dual clamp set-up is where TUG™ HD® Belt Clamps have been located at two belt sections. Each clamp is engaged by sandwiching the belt between two clamp bars that are squeezed together by two clamp ends. These clamp ends are rapidly snugged-up with the T-handles and then tightened with a torque wrench. The clamps are then drawn together using come-alongs furnished by the user in addition to the torque wrench and perhaps box wrenches.

### Single Clamp Application

When only one section of a conveyor belt is required to be temporarily restrained, come-alongs may be attached to the conveyor framework to pull on a single TUG™ HD® Belt Clamp. The belt may be pulled two feet or over twenty feet.

## General Safety Rules – Save These Instructions

Your TUG™ HD® Belt Clamp has been engineered to provide performance, long term economics, and safety advantages that no other type can match. However, even a well-designed and well-built belt clamp can malfunction or become hazardous in the hands of an inexperienced and/or untrained user. Therefore, read this manual and related equipment manuals thoroughly before operating your TUG™ HD® Belt Clamp to provide maximum safety for all operating personnel, and to get the maximum benefit from your equipment.

---

### Signal words

---

“DANGER” indicates an imminently hazardous situation which, if not avoided, **will** result in death or serious injury. The signal word is limited to the most extreme situations.

“WARNING” indicates a potentially hazardous situation which, if not avoided, **could** result in death or serious injury.

“CAUTION” indicates a potentially hazardous situation which, if not avoided, **may** result in minor or moderate injury. It may also be used to alert against unsafe practices.

---

### International Safety Symbol

---



This international safety symbol is used to identify and call attention to specific safety matters.

---

### Safety Information

---

To Avoid Severe Personal Injury or Property Damage, read carefully and understand the following Safety Precautions.

### 1. WORK AREA SAFETY

#### DANGER

Do not allow bystander, visitor, or children in work area during tool operation.

#### WARNING

Store tools outside the reach of children and untrained persons. Tools are dangerous in the hands of unskilled users.

#### CAUTION

Keep work area clean and well lit. Clutter and dark areas invite accidents.

### 2. PERSONAL PROTECTIVE EQUIPMENT

#### WARNING

**EYE PROTECTION** which conforms to ANSI specifications and provides protection against flying particles both from the FRONT and SIDE should ALWAYS be worn by the operator and others in the work area. Eye protection is required to guard against flying debris, which could cause severe eye injury.

The employer and/or user must ensure that proper eye protection is worn. Eye protection equipment must conform to the requirements of the American National Standards Institute, ANSI Z87.1 and provide both frontal and side protection. **NOTE:** Non-side shielded spectacles and face shields alone do not provide adequate protection.

---

## TUG™ HD® Belt Clamp

### ⚠ CAUTION

**HEARING PROTECTION** will be required in some environments. For example, the working area may include exposure to noise level which can lead to hearing damage. The employer and user must ensure that any necessary hearing protection is provided and used by the operator and others in the work area.

### ⚠ CAUTION

**HEAD PROTECTION** – Some environments will require the use of head protection equipment. When required, the employer and user must ensure that head protection conforming to ANSI Z89.1 is issued.

**FOOT PROTECTION** – Safety footwear should always be worn. Operators must be protected against falling tools, stepping on nails and rivets, and slippery conditions.

**HAND PROTECTION** – Safety gloves should always be worn against hot surfaces and other sharp objects.

### 3. BELT TENSIONING

#### ⚠ WARNING

Always align clamp bars square to belt

Always use two (2) come-alongs with safety overload handles.

Always tension clamp ends evenly.

Connect come-alongs to pull parallel to the belt.

Each come-along **must not exceed half the rated load** capacity of the belt clamp.

Never exceed rated load capacity of the belt clamp.

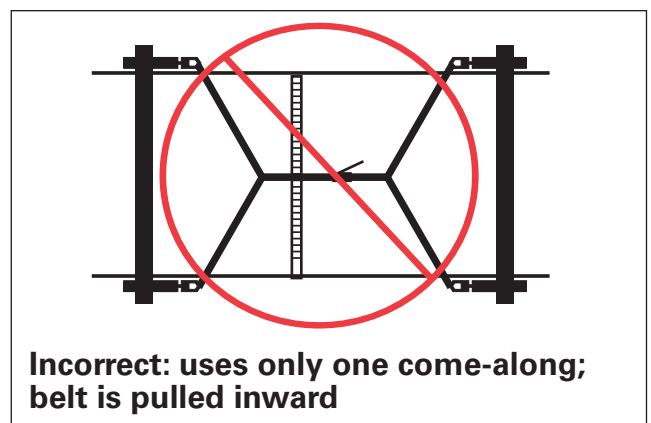
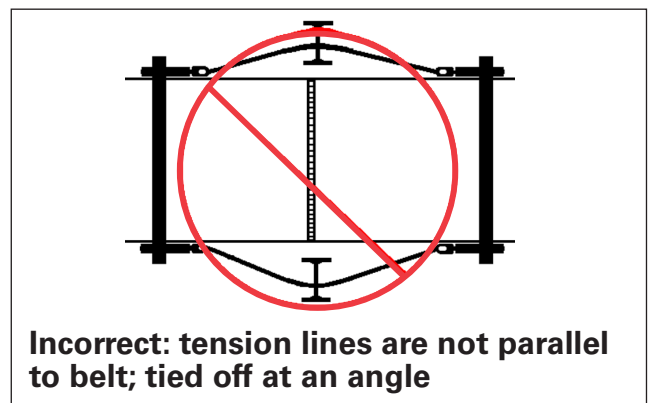
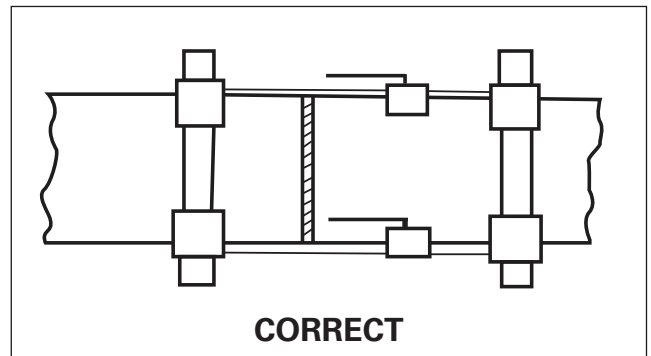

# Pre-Operative Checklist

This checklist must be checked prior to each use of the TUG™ HD® Belt Clamp. This checklist is to be used as a guideline in conjunction with the application, maintenance, and inspection procedures outlined in this manual. The TUG™ HD® Belt Clamp and related equipment must be thoroughly inspected prior to each use by a trained person. A trained person is one who has read and thoroughly understands this instruction manual and related equipment manuals and, through training and experience, has shown knowledge regarding the safe operational procedures. If you do not have such a person in your organization, please contact Flexco or local distributors and they will assist you in providing such a “trained person.” Do not permit any person who is not fully trained to operate TUG™ HD® Belt Clamp. It must be emphasized that the most serious hazards encountered in the application of belt clamps do not arise from the clamps themselves; they are associated with the conveyor system.

### 1. PRELIMINARY SAFETY CHECKS

#### **DANGER**

Lockout/Tagout: Follow OSHA procedures to prevent unexpected start-up of the conveyor.

Take-Up Devices: These devices maintain a constant tension on the conveyor belts. They must be blocked and isolated before maintenance is undertaken.

Sloped Conveyor Belts: Gravity loads on sloped belts may give rise to significant belt tension during maintenance activities. The belts must be blocked before maintenance is begun. Recall that TUG™ HD® Belt Clamps are often used as restraining devices.

### 2. WORK AREA SELECTION

#### **WARNING**

The area must be free from trip and slip hazards.

Work area is to be kept clear of unauthorized personnel at all times. Place barricaded or secure the area in such a manner that no personnel can be injured.

The work space should be unencumbered.

Proper safety railings must be available.

Adequate lighting is a safety requisite.

#### **DANGER**

Avoid explosive atmospheres and combustible materials.

#### **CAUTION**

Stay away from excessive construction dust and debris. These contaminants affect belt friction and clamping efficiency.

### 3. INITIAL EQUIPMENT STATUS

#### **WARNING**

Insure proper maintenance of equipment before undertaking belt repairs. Inspect all components for visible wear or damage. Do not use equipment if there are worn or damaged components.

1. TUG™ HD® Belt Clamp: clamp bars/clamp ends/decals
2. Come-alongs: chains/hook latches
3. Wrenches: torque wrenches/box wrenches (DO NOT use open end wrenches)
4. Catwalks: toe boards/safety railings

### 4. OPERATING PERSONNEL

1. Operators must be thoroughly trained before operating the TUG™ HD® Belt Clamp and associated equipment. A trained person is one that has read and thoroughly understands this instruction manual and related equipment manuals, and through training and experience, has shown knowledge regarding the safe operational procedures.
2. All crew members at the work site must wear personal protective equipment as defined by their employer. (Safety Eyewear, Work Boots, Hard Hat, Etc.)
3. Do not use the TUG™ HD® Belt Clamp or associated equipment when you are tired or fatigued.
4. Do not operate the TUG™ HD® Belt Clamp or associated equipment when under the influence of drugs, alcohol, or medication.

# Operating Instructions

1. Select position where clamp/clamps are to be used, clean belt of all forms of dirt, moisture, oils, etc., unscrew both clamp screws, remove end assemblies and separate the bars ensuring they are 90 degrees to the belt. Ensure clamps are placed no less than 2 feet from belt end.
2. Place the top bar into position, ensuring it is 90 degrees to the belt. Slide the clamp ends over the top bar. Position and slide the bottom bar into the clamp end and under the belt. Ensure the grip pattern on each bar is facing belt surface.
3. Ensure that clamp ends are placed against each edge of the conveyor belt.
4. Use torque wrench to ensure the correct torque value is applied to the clamp end screws.
5. Securely attach hooks on come-along chain to clamps.
6. Evenly apply tension to pull belt to desired position.

 **DANGER** Never exceed rated load capacity.

7. To remove the clamps after maintenance is complete slowly loosen all clamp screws allowing tension in the belt to release. Remove come-along chains and clamps.

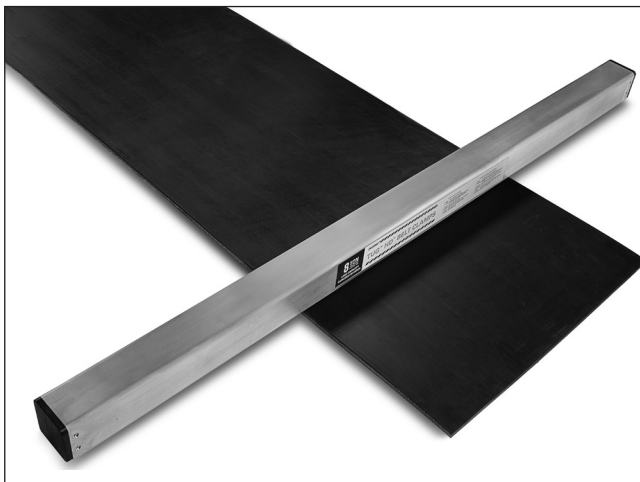

1. Place the top bar into position, ensuring it is 90° to the belt edge.

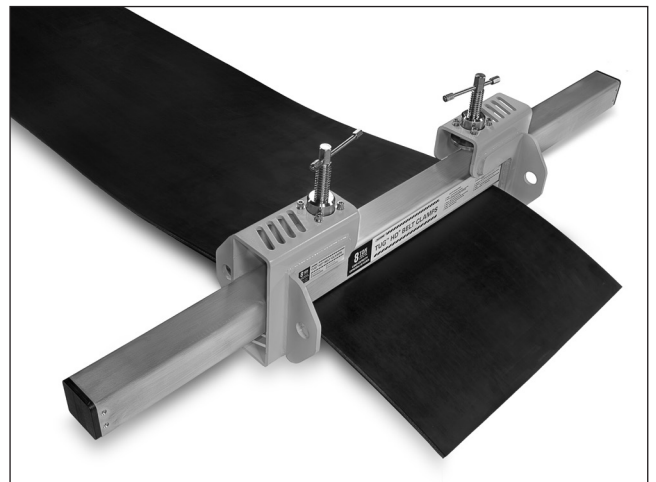

2. Slide the clamp ends inboard over the top bar so that the throat touches the edge of the belt.

## TUG™ HD® Belt Clamp



3. Slide the bottom bar into the clamp end and under the belt. Ensure the grip pattern on each bar is facing the belt surface.

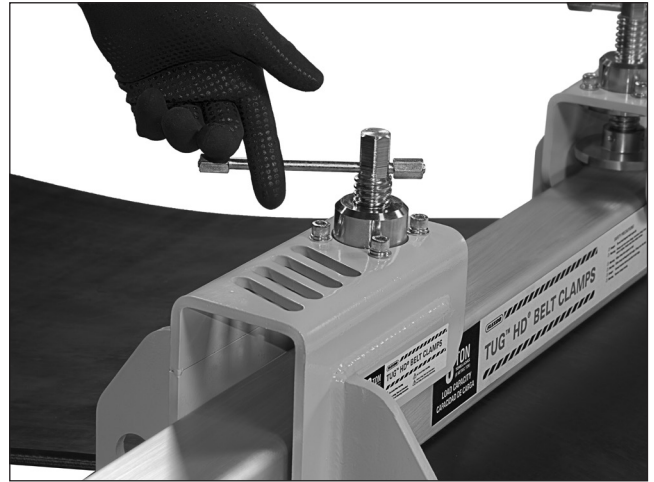

4. Use the T-handles to rapidly snug-up the clamp end screw against the belt. Do not hammer the T-handles to tighten the clamp ends. **The T-handles are not to be used to fully tighten the clamp end screws. They will bend.**



5. Use 20 mm hex head torque wrench to apply the correct torque value to the clamp end screws.

 **WARNING** – Beware of extreme High or Low torque values.

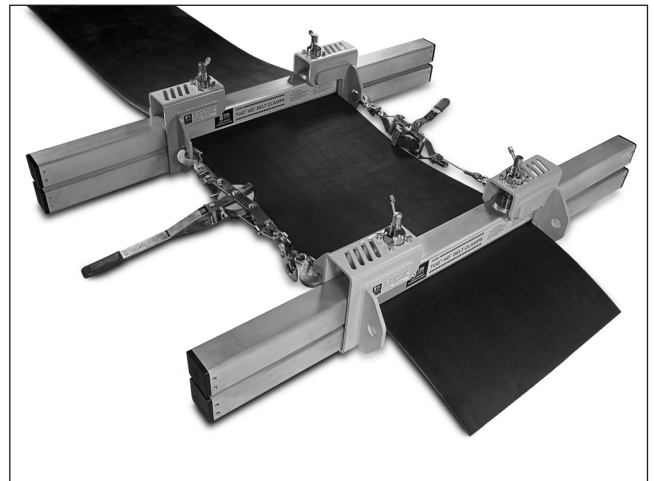

6. Securely attach come-alongs to the clamp ends using the hook safety latches. Evenly apply tension to pull belt to desired position.

 **DANGER** – Never exceed rated load capacity.

7. To remove the clamps after maintenance is complete slowly loosen all clamp screws allowing tension in the belt to release. Remove come-along chains and clamps.

Flexco Europe GmbH • Maybachstrasse 9 • 72348 Rosenfeld • Germany  
Tel: +49-7428-9406-0 • Fax: +49-7428-9406-260 • E-mail: europe@flexco.com

Visit [www.flexco.com](http://www.flexco.com) for other Flexco locations and products.

©2017 Flexible Steel Lacing Company. 05-27-20. For reorder: X4671

